

**H03** SISTEMA 2 VIE REFLEX  
120 WATT

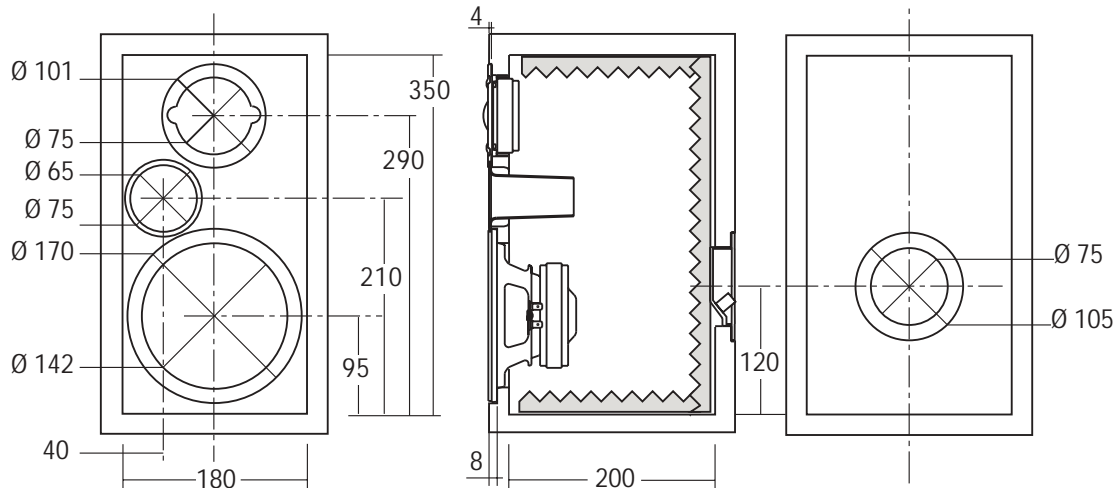

**COMPONENTI**  
HW 161 N  
HT 262  
Kit Filtro autocostruito



**PRODOTTO** BOX GREZZO: BH03  
multistrato di betulla



**PRODOTTO** FILTRO IN KIT: KFH03



**SCHEMA PER AUTOCOSTRUZIONE FILTRO**

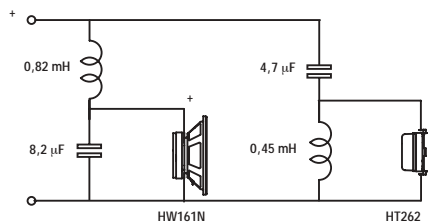

**COMPONENTI** N°1 HW 161 N, N°1 HT 262

Impedenza **8 Ω**  
Potenza massima **120 W**  
Potenza nominale **60 W**

**CARATTERISTICHE TECNICHE**

Volume netto Vb **12 dm<sup>3</sup>**  
Lunghezza tubo di accordo **83 mm**  
Frequenza accordo Fb **66 Hz**  
Materiale Box autocostruito **Multistrato/MDF/Truciolare**  
Spessore consigliato **15/20 mm**

**RISPOSTA IN FREQUENZA (1W/1m)**

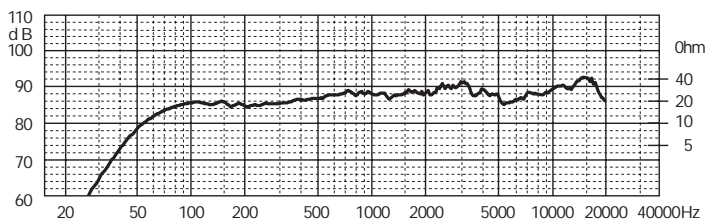

**NOTE:** Attenuazione opzionale tweeter: Resistenza in serie (1,6 Ω/10 W); resistenza in parallelo (30 Ω/10 W).

**ACCESSORI**

Tubo di accordo	<b>YAC413</b>	Inseri per spikes	<b>YAC225</b>
Materiale fonoassorbente	<b>YAC826</b>		
Vaschetta portaterminali	<b>YAC006</b>		
Cavo per collegamenti	<b>CA0215T</b>		
Fonoisolante per cavi	<b>YAC835</b>		
Guarnizione sigillante	<b>YAC830</b>		
Viti per fissaggio altoparlanti	<b>YAC246</b>		
Punte da appoggio (spikes)	<b>YAC230</b>		